

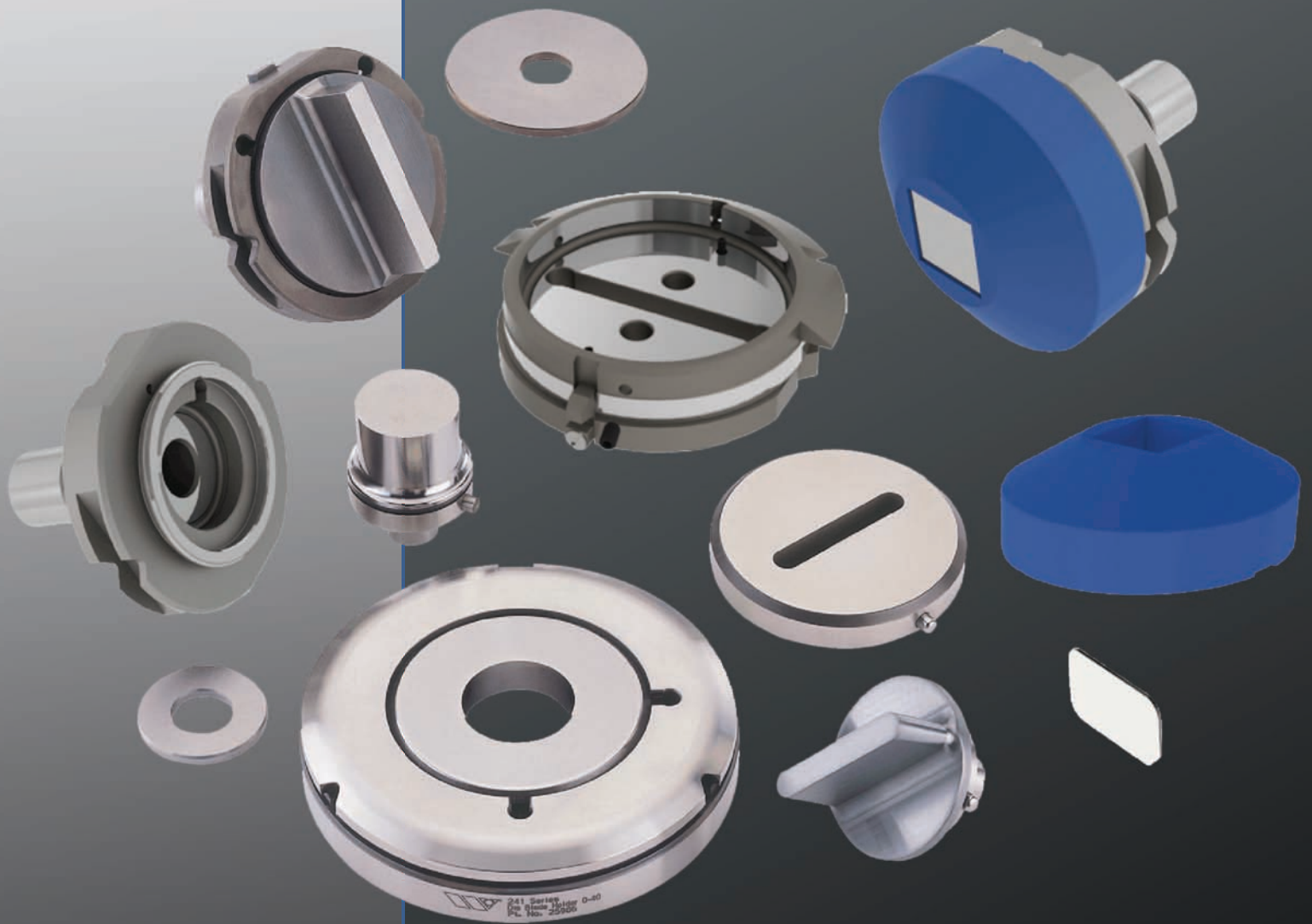

WILSON 2-4-1 SYSTEM

TWICE THE LIFE
TWICE THE VALUE



WILSON 2-4-1 SYSTEM

Extending tool life in
Trumpf-style tooling!

Developed for users of Trumpf, Pullmax, Boschert and Euromac machines, the Wilson 2-4-1 System of punches and dies is designed to extend tool life and reduce set-up times. Following their introduction in 2005, 2-4-1 punches and dies have become the new standard for many Trumpf-style tooling users.

Wilson 2-4-1 punches incorporate a high-precision spacer to increase tool life to an unprecedented 6mm and a keyed punch for accurate, repeatable tool set-up. Now available, the Wilson 2-4-1 Plus Punch System upgrades this original concept with push-on urethane strippers for reduced sheet marking and a dry-wipe insert to easily record your tool size.

With a unique design that incorporates a die holder, die blade and precision spacer, the Wilson 2-4-1 Die System has 2mm of regrind life – twice the life of a standard Trumpf-style die. Introduced in 2009, the Wilson 2-4-1 Slitting Die System extends these principles to slitting dies. With a tough integrated die shoe-die holder design and Ultima™ steel die blades, this new system can increase tool life by up to four times in slitting applications.

There is no greater value than the Wilson 2-4-1 System. With punches and dies that offer twice the amount of grind life, Wilson 2-4-1 tooling delivers maximum value along with the assurance of quality and accuracy offered by Wilson Tool. Wilson 2-4-1 is like getting two tools for the price of one.

One more way Wilson Tool International strives to make its customers

“the most successful
fabricators in the world.”

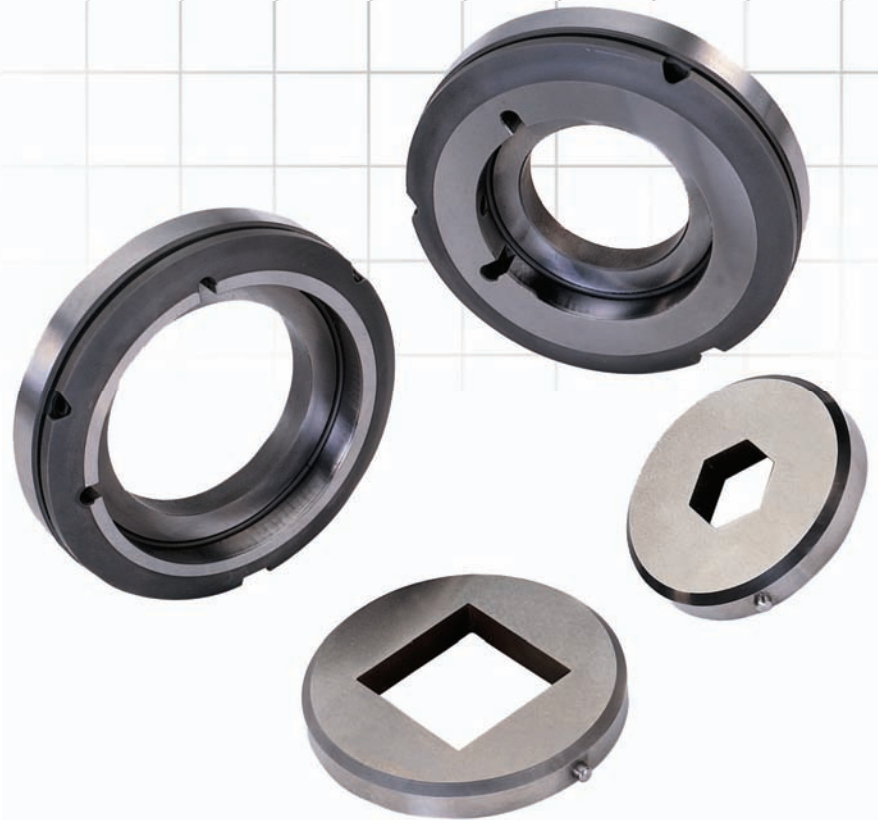

Wilson 2-4-1 Die System

Benefits/Specifications:

- Die assemblies include precision shims for 2mm of grind life, twice the life of a standard Trumpf-style die.
- Two-piece die design with die holder manufactured from shock-resistant steel and die blade manufactured from high speed steel for long life.
- Die blades can be replaced rather than a complete solid-style die for maximum value.

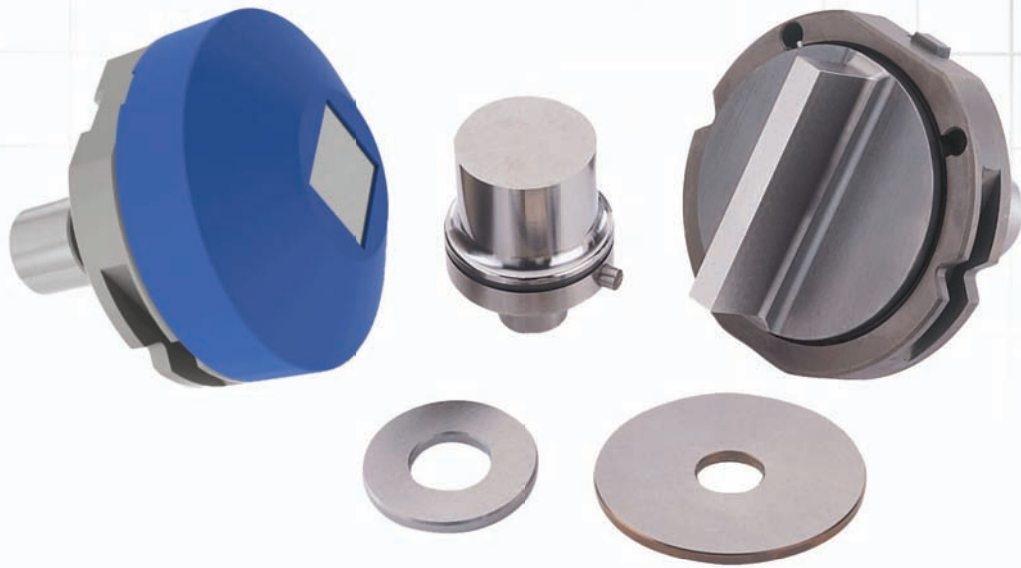

Wilson 2-4-1 Plus Punch System

Benefits/Specifications:

- Punch assemblies include a precision spacer for 6mm of grind life.
- Punches are available in Ultima™ tool steel and with Optima coating for extended tool life.
- A built-in collar and keyed punch ensure accurate, repeatable tool set-up without the need for an alignment fixture.
- Fixed angular setting eliminates the chance of setting errors to reduce scrap.
- Punches are unable to move in the collar while under a heavy load.
- Two punch holders available: 0 to 40mm and 40 to 76.2mm.
- Push-on urethane stripper available for the 0 to 40mm assembly for reduced sheet marking.
- Includes a magnetic ID pad to easily record tool size.



Size 40mm - 76.2mm

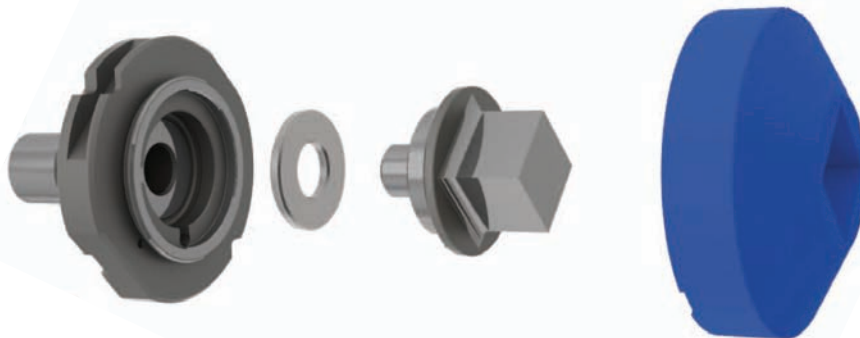

Size 0mm - 40mm

Wilson 2-4-1 Slitting Die System

Benefits/Specifications:

- Designed specifically for slitting operations.
- Die assemblies include precision shims for 2mm of grind life, twice the life of a standard Trumpf-style die.
- Die holders are manufactured from shock-resistant steel for long life.
- Die blades can be replaced rather than a complete solid-style die for maximum value.
- Two assembly sizes available: 0 to 56mm and 56 to 76.2mm
- 56 to 76.2mm die holder and die shoe are integrated in a single component for increased strength and toughness.
- 56 to 76.2mm die blades are manufactured from Ultima™ tool steel for more hits between regrinds and reduced down-time.



For slitting sizes up to 56mm long

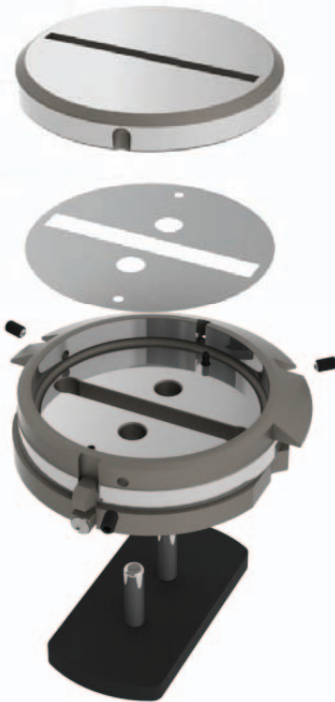

For slitting sizes up to 76.2mm long

Wilson 2-4-1 Heavy Duty Die

Benefits/Specifications:

- A special 2-4-1 die holder assembly, designed for complex two-dimensional shapes and cluster tools with small webs between holes.
- An aperture is cut into the die holder to fully support the die blade. Note: special shims are provided.
- Die assemblies include precision shims for 2mm of grind life, twice the life of a standard Trumpf-style die.
- Die holders are manufactured from shock-resistant steel for long life.
- Die blades can be replaced rather than a complete solid-style die for maximum value.



Wilson 2-4-1 System

Example Cost Justifications

Wilson 2-4-1 Punch System (Standard Length Tooling)

With 6mm of grind life, Wilson 2-4-1 punches last twice as long as conventional Trumpf-style punches.

- ⇒ *The cost of a 2-4-1 punch holder and rectangle slitting punch insert = £211.00*
- ⇒ *The cost of three conventional Trumpf-style slitting punches = £228.00*

After payback has been made and with twice the life of conventional punches, you will then see ongoing savings of £66.00 every time you purchase a replacement 2-4-1 punch.

Wilson 2-4-1 Punch System (Long Tooling)

With 9mm of grind life, Wilson 2-4-1 punches last 1.5 times as long as conventional Trumpf style punches.

- ⇒ *The cost of a 2-4-1 punch holder and rectangle slitting punch insert = £211.00*
- ⇒ *The cost of three conventional Trumpf-style slitting punches = £228.00*

After payback has been made and with 1.5 times the life of conventional punches, you will then see ongoing savings of £28.00 every time you purchase a replacement 2-4-1 punch.

Wilson 2-4-1 Slitting Die System

With 2mm of grind life and Ultima™ Steel die blades, Wilson 2-4-1 slitting die blades last at least four times as long as conventional Trumpf-style slitting dies.

- ⇒ *The cost of a 2-4-1 tool holder and die Blade = £298.49*
- ⇒ *The cost of four conventional Trumpf-style slitting dies = £288.00*

After payback has been made and with four times the life of conventional dies, you will then see ongoing savings of £189.00 every time you purchase a replacement die blade.

WILSON TOOL INTERNATIONAL (EUROPE) LTD

United Kingdom

European Headquarters

Stirling Road, South Marston
Industrial Estate, Swindon, Wiltshire
SN3 4TQ, United Kingdom
Tel (Free): 0800 373748
Tel: +44 (0)1793 831818
Fax (Free): 0800 373758
Fax: +44 (0)1793 831945
email: sales@wilsonstool.eu.com

France

Bat B,
51 Rue d'Ourdy, 77550 Réau, France
Tel: (Gratuit) 0800 10 29 00
Tel: +33 (0)1 64 13 47 80
Fax: (Gratuit) 0800 10 40 14
Fax: +33 (0)1 64 13 47 81
email: ventes@wilsonstool.eu.com

Germany

Gottlieb Daimler Str 2
31552 Rodenberg, Germany
Tel: (Frei) 00800 945 766 8665
Tel: +49 (0)5723 747 0
Fax: (Frei) 00800 945 766 329
Fax: +49 (0)5723 747 10
email: verkauf@wilsonstool.eu.com

Scandinavia

Islevdalvej 100
DK-2610, Rødovre, Denmark
Tel (Free): 80 20 20 24
Tel: +45 44 53 16 99
Fax (Free): 80 20 20 26
Fax: +45 44 53 06 07
email: salesdk@wilsonstool.eu.com

email: sales@wilsonstool.eu.com

Visit us online at: www.wilsonstool.com

United States

Worldwide Headquarters

12912 Farnham Avenue
White Bear Lake, MN 55110 USA
Tel (Free): 800 328 9646
Tel: (651) 426 9133
Fax (Free): 800 222 0002
Fax: (651) 426 9134
email: marketing@wilsonstool.com

Argentina

Wilson Tool International(r), Argentina
Von Wernicke 3041 PB
San Isidro, 1642 Buenos Aires
Argentina
Tel: +54 114 7634004
Fax: +54 114 5084190
email: ventasargentina@wilsonstool.com

China

No. 6 Building of 58
4018 Lane Huaning Road
Xinhuang Industry Park
201108 Shanghai, China
Tel: +86 21 51089638
Fax: +86 21 64422195
email: sales@wilsonstool.cn

South Africa

Wilson Tool South Africa Limited
Rynhurst Business Park
156 Pretoria Road
Rynfield
Benoni
1501
Gauteng
Republic of South Africa
Tel: +27 877 217 875
Fax: 086 657 8629
email: simon.penney@wilsonstool.com

Mexico

The Wilson Company SRL de CV
BLVD. Diaz Ordaz no 140 piso 20
Col. Santa Maria
Monterrey, Nuevo Leon
Mexico
C.P. 64650
Tel: 52 (81) 8865 4820
Fax: 52 (81) 8865 4599

